

Gary



nicoline

Descrizione modello - *Model Description*

Dimensioni - *Dimensions*

Composizioni consigliate - *Recommended compositions*

nicoline.it

ITALY - C.da Parchi Calia sn Z.I. - 70022 Altamura – BA - Telefono: +39 080 3101487

UNITED STATES - Nicoline Salotti Inc. po box 38783 - Greensboro – NC 27438 - Phone: +1 (336) 259 9881

SINGAPORE - 23 Genting Road #06-01 - Chevalier House Singapore 349481 - Telefono: +65 8168 3354

GARY

Design Application N° 008642821-0007



frontale // front

laterale // depth

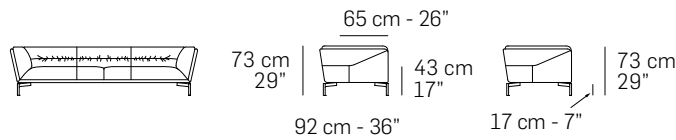

Caratteristiche standard

- Struttura in multistrato, massello di abete e base in MDF con rinforzi in metallo, molleggio seduta con cinghie elastiche.
- Imbottiture in poliuretano espanso ecologico a cellula aperta con densità differenziate.
- Rivestimento in pelle o tessuto. Tutti i rivestimenti sono fissi.
- Piede in metallo Canna di fucile (Cod.50), Ottone satinato (Cod.51), Bronzo anticato (Cod.52).
- Elementi Cod.1421 - 1422 - 1671 - 1672 - 3031 - 3032 - 3521 - 3522 - 9507 con ripiano in marmo Bianco Carrara (Cod.CA).
- Le cuciture per il rivestimento in pelle sono realizzate nel seguente modo: Cucitura Cod.03 per parte perimetrale interna; Cucitura Cod.01 per la restante parte.
- Il rivestimento in tessuto possiede solamente la cucitura Cod.03.
- Inserimento letto non possibile.
- Lato componibile rifinito.

Caratteristiche optional su richiesta senza maggiorazione

- Disponibile con cucitura a contrasto, per la scelta del colore fare riferimento ai codici del campionario pelli.

Caratteristiche optional su richiesta con maggiorazione

- Per il multi rivestimento il prezzo va incrementato del 7%. Per maggiori dettagli fare riferimento al paragrafo "NOTE" posto nelle prime pagine del listino.
- Elementi Cod.1421 - 1422 - 1671 - 1672 - 3031 - 3032 - 3521 - 3522 - 9507 con ripiano in marmo Emperador (Cod.EM), Nero Marquinia (Cod.NM).

Note

- I disegni grafici che riportano l'asterisco (*) sono sempre con lato rifinito e anche agganciabili agli elementi componibili
- Non è possibile applicare altre cuciture.
- Per alcuni tessuti e velluti l'azienda si riserva di applicare la cucitura Cod.00 / Cod.03 (vedi immagine).

Standard features

- Frame: wooden structure, solid fir wood with MDF base with metal reinforcements, seat suspensions in reinforced elastic webbing.
- Paddings in eco-friendly open cell polyurethane foam, with different densities.
- Covering in leather or fabric. Not removable coverings.
- Metal legs in Gunmetal (Cod.50), Satin Brass (Cod.51), Antique bronze (Cod.52).
- Versions Cod.1421- 1422- 1671- 1672- 3031- 3032- 3521- 3522 - 9507 with top in White Carrara marble (Cod.CA).
- Stitchings only for leather covering are being placed as per the following: Stitching type Cod.03 for the inner perimeter part; Stitching type Cod.01 for the remaining part.
- Stitching type Cod.03 only for fabric covering.
- No bed version available.
- Sectional sides finished.

Optional features available upon request without any upcharge

- Stitching, unless differently requested, will be matching the leather or fabric colour. Contrast stitching colour can be ordered at no extra charge. You might use as reference any Noline leather.

Optional features available upon request with an upcharge

- 7% upcharge for combined coverings. Please refer to the notes at the beginning of pricelist.
- Versions Cod.1421- 1422- 1671- 1672- 3031- 3032- 3521- 3522 - 9507 with top in Emperador marble (Cod.EM), Black Marquinia marble (Cod.NM).

Notes

- Versions with asterisk (*) have always the finished terminal side with the possibility to be connected to modular elements.
- Different stitchings not available.
- For some fabrics and velvets production dept. must apply the stitching Cod.00 / Cod.03 (as per picture below).



Piede in metallo // Metal legs



Canna di Fucile (Cod.50) // Gunmetal (Cod.50)



Ottone Satinato (Cod.51) // Satin Brass (Cod.51)



Bronzo Anticato (Cod.52) // Antique Bronze (Cod.52)



Elementi // Versions



Marmo Bianco Carrara (Cod.CA) // Withe Carrara marble (Cod.CA)



Marmo Emperador (Cod.EM) // Emperador marble (Cod.EM)

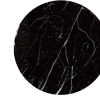

Marmo Nero Marquinia (Cod.NM) // Black Marquinia marble (Cod.NM)

Cuciture // Stitching

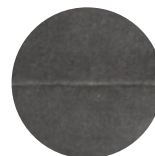

Cod.00

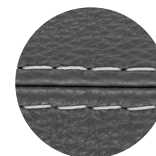

Cod.01

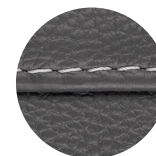

Cod.03

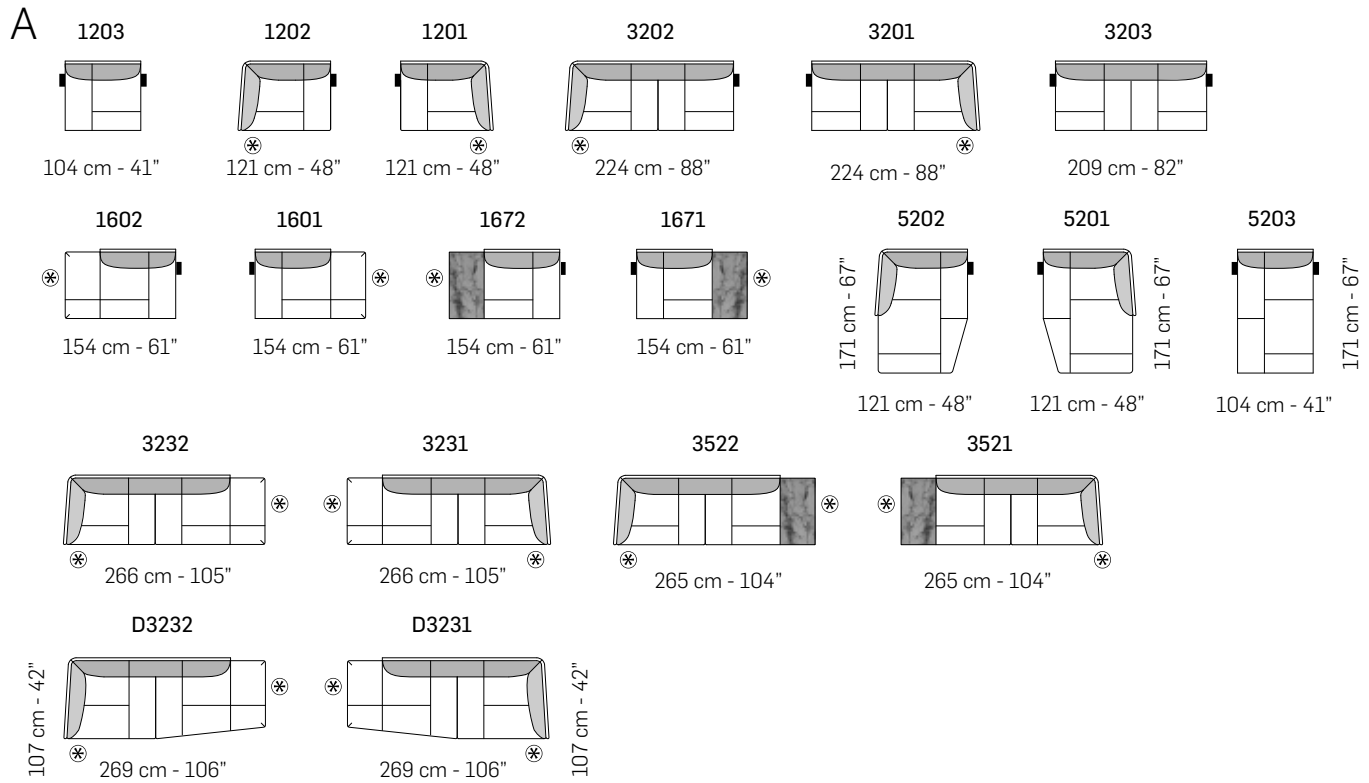
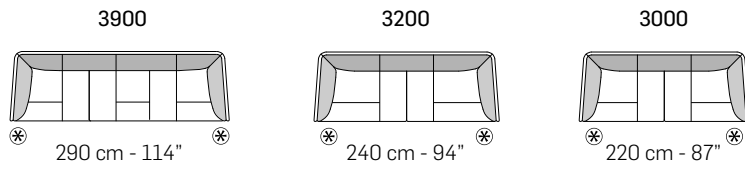

tutti gli elementi del gruppo A hanno lo stesso modulo di seduta - all items in group A have the same seat width

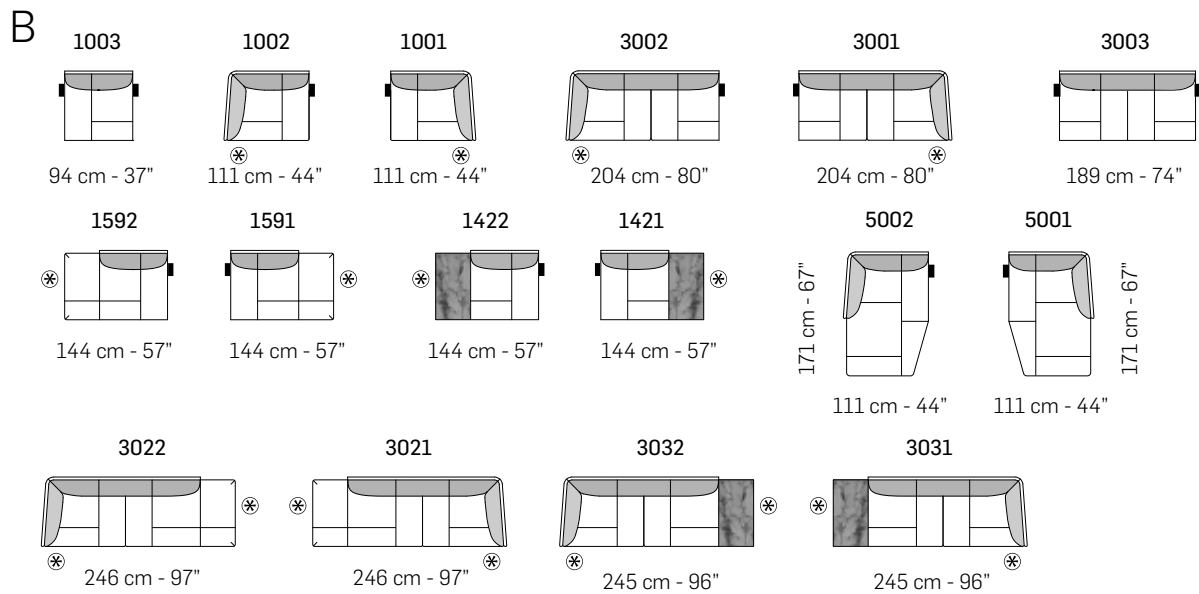

tutti gli elementi del gruppo B hanno lo stesso modulo di seduta - all items in group B have the same seat width

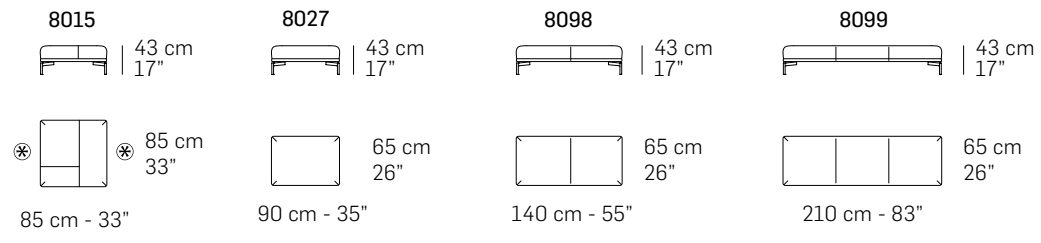
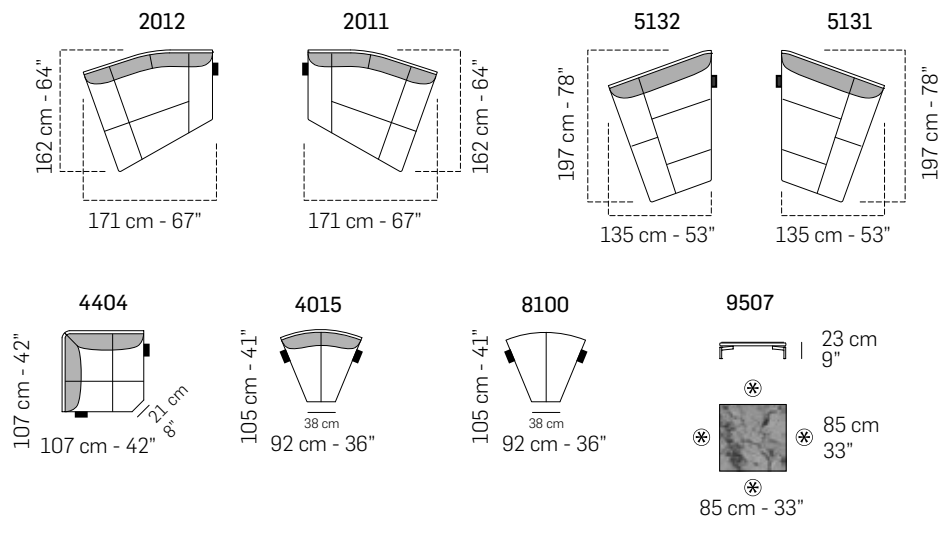

CUSCINETTI CONSIGLIATI / SUGGESTED PILLOWS

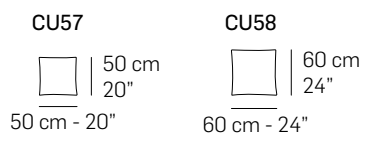

COMPOSIZIONI CONSIGLIATE / SUGGESTED COMPOSITIONS

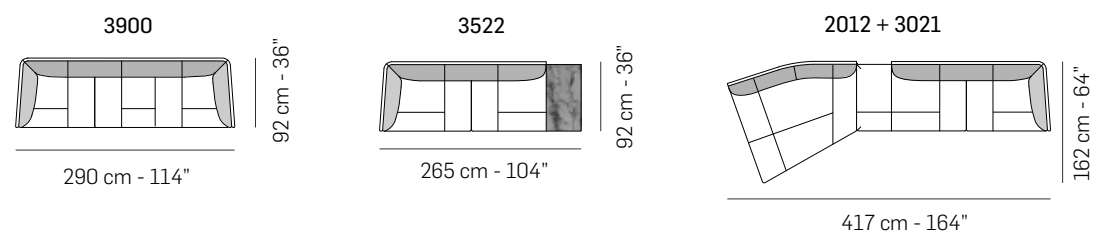

Scala 1:100
Ratio 1 to 100

Legenda / Legend

- Spalliera / Back Cushions
- Bracciolo / Armrest
- Marmo / Marble
- Poggiareni / Kidneyrest
- Seduta / Seat Cushions
- ⊗ Lato terminale sempre rifinito e agganciabile agli elementi componibili / Terminal side is always finished and it can also be connected to modular elements
- Aggancio Componibile / Connector

Note / Notes

Nicoline si riserva il diritto di apportare in ogni momento modifiche tecniche ed estetiche / Nicoline reserves the right to change, at any time and without prior warning, technical and aesthetic specifications of the articles.